

Position Sensing with Magnetostrictive Devices Improving Precision using TDCs

Non-contact, linear position sensing is necessary for many industrial applications. Magnetostrictive transducers in addition offer a very high precision of less than 0.001 inch. They are well established in applications like plastic injection molding machines, hydraulic and pneumatic cylinders or wood-working machinery. A basic challenge for the electronics is high-precision time measurement and can be easily solved using TDCs (Time-to-Digital Converter)

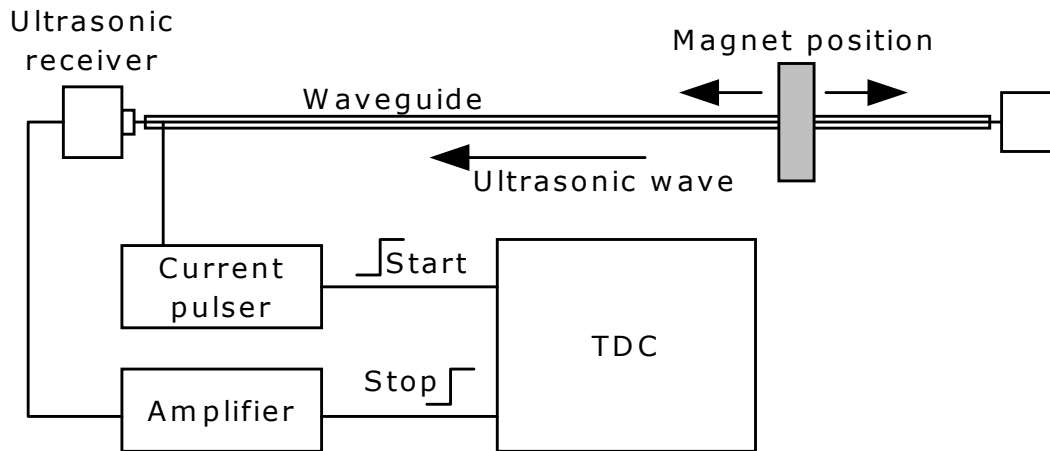

The Measuring Principle

The measuring element consists of a magnetostrictive waveguide. Magnetostrictive materials are elastically deformed when a magnetic field is present. This effect is used in the following manner:

The magnetostrictive waveguide is built as tube with a copper rod inside. The start of measurement is initiated by a short current pulse. This produces a circular magnetic field around the waveguide. The position of the movable part is marked by a magnet whose magnetic field is perpendicular to the circular field of the current pulse. The interaction between the two magnetic fields produces a strain pulse, which travels at sonic speed along the waveguide. A sensor placed at the end of the waveguide converts the sonic pulse into an electrical signal. The travel time is directly proportional to the position of the magnet. The sonic speed in the waveguide is approximately 2830m/s, which corresponds to approx. 9µs/inch or 0.35µs/mm. To achieve a resolution of 0.0002 inches (5µm), the precision in time measurement must be 1.8ns! This corresponds to a reference clock in the GHz range.

Time Measurement with TDCs

TDC-GP1 is a good solution for the time measurement task in magnetostrictive applications. This single-chip time-to-digital converter has 2 channels with

a single shot resolution of 250ps and therefore easily fulfills the needs of high precision positioning. Furthermore, the 30bit dynamic range of TDC-GP1 allows measurements up to 200ms with the same resolution. With its 4-fold multihit capability up to 4 magnets can be handled at once. TDC-GP1 is available in a small TQFP44 package allowing compact board design.

Several different measurement modes are available with TDC-GP1. For magnetostrictive applications the one called 'measurement range 2' is the right choice. In this mode, the TDC uses a predivider to extend the measurement range from 7.6µs to 200ms.

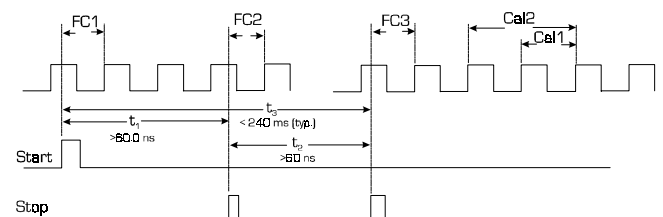

When the TDC is started, the time difference between start and the next rising edge of the calibration clock is measured by the measuring unit with 250ps resolution (FC1 - finecount1). Afterwards a 16 bit counter is activated that counts the periods of the predivider ((cc - coarse count). The time between stop pulse and next rising edge of the reference counter is measured again with 250ps resolution (FC2 - finecount2). In the following, one and two peri-

ods of the calibration clock are measured for calibration (cal1, cal2).

The final time is calculated as:

$$time = T_{ref} * 2^{SEL_CLK_TDC} * \left(cc + \frac{FC1 - FC2}{Cal2 - Cal1} \right)$$

cc=value of the precounter

T_{ref} = Period of reference clock (500kHz - 35MHz)

SEL_CLK_TDC = programmable value (0 ... 6)

The data format is a 32 bit floating point number, that has to be multiplied by $T_{ref} * 2^{SEL_CLK_TDC}$. For data transfer the TDC-GP1 has a standard 8-bit interface.

Resolution

The resolution (LSB) of the TDC is 250 ps over the total measurement range. This corresponds to a displacement of

$$Resolution \text{ (LSB)} = 0.000028 \text{ in } (0.7 \mu\text{m})$$

Measurement Range

The maximum of the measurement range is defined as:

$$T_{max} = T_{ref} * 2^{SEL_CLK_TDC} * 2^{16}$$

with $(2 * T_{ref} * 2^{SEL_CLK_TDC} < 7.6 \mu\text{s})$

Example:

Working with a 8 MHz reference clock, T_{ref} is 125ns. Setting SEL_CLK_TDC to 0, the maximum time is 8.192 ms.

For magnetostrive positioning this means that the maximum rod length is > 905 in (23 m)

The minimum of the measurement range is defined as:

$$T_{min} = 1.5 * (T_{ref} * 2^{SEL_CLK_TDC}) + 25 \text{ ns.}$$

Example:

Working with a 8 MHz reference clock, T_{ref} is 125ns. Setting SEL_CLK_TDC to 0, the minimum time is 212,5 ns.

For magnetostrive positioning this means the minimum distance is 0.024 in (601 μm).

Multihit capability

In measurement range 2 only one stop channel is available. It's the stop 1 input that is enabled. This channel has 4-fold multihit capabilities in normal resolution mode. Always the time between stop and start is measured.

The double pulse resolution is given by:

$$T_{dp} = 1.5 * (T_{ref} * 2^{SEL_CLK_TDC}) + 25 \text{ ns.}$$

Example:

Working with a 2 MHz reference clock (500ns) and setting SEL_CLK_TDC to 0, the double pulse resolution is 850 ns.

For magnetostrive positioning this means that the minimum distance between two magnets is 0.094 in (2.4 mm)

Programming TDC-GP1

In the following we'll show how to programm the TDC-GP1 in two different applications.

Measurement example 1:

Lets take a simple magnetostrictive system with only one magnet, that cannot be removed. The reference clock shall be 2MHz.

The program is split into two main blocks: the configuration routine, where the control registers are set, and the measurement routine.

Configuration:

```
output_byte(Reg7, 0x0)
output_byte(Reg0, 0x78);
output_byte(Reg2, 0x21);
output_byte(Reg4, 0x00);
output_byte(Reg6, 0x01);
output_byte(Reg7, 0x02);
```

Disbale inputs while writing to control registers
 Set Measurement range 2, use autocalibration
 Calculate Stop1 – Start
 Set SEL_CLK_DIV to 0
 Set Interrupt to ‚ALU ready‘, medium ALU-speed
 Enable 2 hits on channel 1 (Start and Stop1)

Measurement:

```
while(!quit)
{
    output_byte(Reg11,0x07);
    valid = 0;
    while(valid==0)
    {
        valid=input_byte(INTFLAG);
    }
    nk0=input_byte(Reg0);
    nk1=input_byte(Reg0);
    vk0=input_byte(Reg0);
    vk1=input_byte(Reg0);

    vk1=vk1 * 256;
    vk1=vk1|vk0;
    nk1=nk1 * 256;
    nk1=nk1|nk0;

    result = 500.0 * ((float)[vk1]+(float)[nk1]/65536.0);
    position = result + 0.005570866;
    printf("position = %6.3f in\n",result);
}
```

Init TDC and ALU, Now the TDC is ready to measure

Check Interrupt Flag, if '1', data are available in output register

Lower byte xxxx.xxXX
 Higher byte xxxx.XXxx
 Lower byte xxXX.xxxx
 Higher byte XXxx.xxxx

shift left
 XXXX.xxxx
 shift left
 xxxx.XXXX

Result in 'ns'. 2 MHz reference clock -> 500 ns
 Position in inch
 Print position in inch

Measurement example 2:

Lets take a complex magnetostrictive system with four magnets. It may be possible to remove any of the magnets. The reference clock again shall be 2MHz.

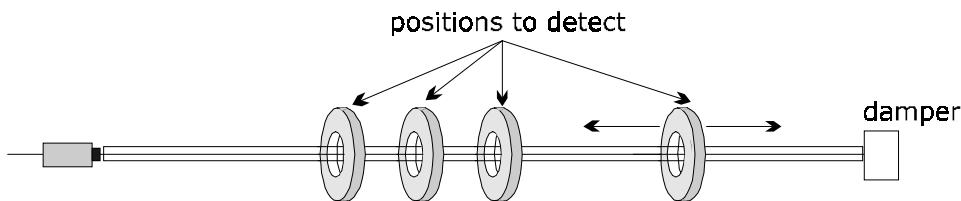

Configuration:

```
output_byte(Reg7, 0x0);
output_byte(Reg0, 0x78);
output_byte(Reg2, 0x21);
output_byte(Reg4, 0x00);
output_byte(Reg6, 0x81);
output_byte(Reg7, 0x02);
```

Disbale inputs while writing to control registers
 Set Measurement range 2, use autocalibration
 Calculate Stop1 – Start, Position of the first magnet
 Set SEL_CLK_DIV to 0
 Set Interrupt to ‚Overflow‘, medium ALU-speed
 Enable 4 hits on channel 1 (Start and Stop1-3) and 1 hit on channel 2 (Stop4, this hit is measured on channel 1, but for internal storage, the registers of channel 2 are used)

Measurement:

```

while(!quit)
{
    output_byte(Reg1,0x07);
    valid = 0;
    while(valid==0)
    {
        status = input_byte(0x8);
        if (status | 0x48) > 0 then
        {
            valid = 1;
            n_hits = status | 0x4 + (staus | 0x8)/8;
        }
    }
    adr_pointer = 2;
    hitx = 0x21;

    For (i=1,n_hits,i++)
    {
        valid=0
        while(valid==0)
        {
            status = input_byte(0x9);
            status = stauts | 0x03;
            if (status==adr_pointer) then
                valid=1;
        }
        adr_pointer = adr_pointer + 2;
        hitx = hitx + 0x10;
        output_byte(Reg2, 0x21);
    }

    For (i=1,n_hits,i++)
    {
        nk0=input_byte(Reg0);
        nk1=input_byte(Reg0);
        vk0=input_byte(Reg0);
        vk1=input_byte(Reg0);

        vk1=vk1*256;
        vk1=vk1|vk0;
        nk1=nk1*256;
        nk1=nk1|nk0;

        result = 500.0*([(float)[vk1]+(float)[nk1]/65536.0]);
        position = result * 0.005570866;
        printf("position %d = %6.3f in\n",i,result);
    }
}

```

Init TDC and ALU

Read Statusregister 1
Check, whether the TDC could measure 4 hits
or if magnets are missing (overflow) }
number of hits (= number of magnets)

number of hit, 0x21 = stop1, 0x31 = stop2 ...

Calculate all hit x - start time differences

Read statusregister 2
Get pointer position in output register
data are available in output register

Register 2 value for calculation of next hit
Start calculation of next hit (magnet)

Data output for all hits

Lower byte xxxx.xx**XX**
Higher byte xxxx.**XX**xx
Lower byte xx**XX**.xxxx
Higher byte **XX**xx.xxxx

shift left
XXXX.xxxx
shift left
xxxx.**XXXX**

Result in 'ns'. 2 MHz reference clock -> 500 ns
Position in inch
Print position in inch

The information provided herein is believed to be reliable. However, acam-messelectronic assumes no responsibilities for inaccuracies or omissions. acam-messelectronic assumes no responsibility for the use of this information, and all use of this information shall be entirely to the user's own risk. No patent rights or licenses to any of the circuits described herein are implied or granted to any third party. acam-messelectronic does not authorize or warrant any acam-messelectronic product for use in life support devices and/or systems.

1. Edition June 2001