



# PICO STRAIN

White Paper

## Temperature Measurement with PS08

07. August 2009  
Document No.: WPO03 V1.0

# Temperature Measurement with PS08 Millikelvin Resolution with only a few Microampere

What new features can we imagine when talking about temperature measurement? This is well established and many solutions are available. However, there are points, which can be improved and simplified. With PS08 we introduce a solution for platinum sensors that combines a very low current consumption of a few  $\mu\text{A}$  with a high resolution of a few mK. Thanks to the minimized current in the sensor the self-heating effect is negligible. The integrated microprocessor can take care of calculating the temperature.

In this white paper we introduce an electronic for measuring the temperature, optionally with display, for a range from  $-50\text{ }^{\circ}\text{C}$  to  $350\text{ }^{\circ}\text{C}$ . It is based on PS08 and offers 3 mK resolution at a current of less than 2  $\mu\text{A}$  into the sensor.

<b>1</b>	<b>Introduction</b>	<b>3</b>
1.1	PS08 PICOSTRAIN Converter	4
1.2	Measuring Principle	4
<b>2</b>	<b>Realization, Variant 1</b>	<b>5</b>
2.1	Configuration of PS08	6
2.2	Program	7
2.3	Results:	8
<b>3</b>	<b>Realization, Variant 2 – Minimized circuit</b>	<b>9</b>
3.1	Configuration of the PS08	10
3.2	Program	10
3.3	Results:	11
<b>4</b>	<b>3-Wire Sensors</b>	<b>12</b>
<b>5</b>	<b>Multiple channels</b>	<b>13</b>
<b>6</b>	<b>Conclusion</b>	<b>14</b>

Autor: Norbert Breyer

## 1

## Introduction

The most common sensor types are resistive sensors or thermoelectric sensors. The solution presented here is for resistive sensors only.

These sensors on the fact that metal changes its resistance with temperature. The resistance increases with temperature, the temperature coefficient is positive. The most common material is platinum. It is preferred due to the constant behavior and repeatability. It works at temperatures and is chemically resistant.

The most common types are PT100 (100 Ohm at 0°C) and PT1000 (1000 Ohm at 0°C). The TK is 0.385 Ohm/K for PT100 or 3.850 Ohm/K for PT1000. This relation between resistance and temperature is non-linear. It can be described by a polynomial of 3rd degree:

$$R(t) = R_0(1 + At + Bt^2 + C(t-100^\circ\text{C})t^3) \quad (1)$$

In the positive temperature range this can be simplified to:

$$R(t) = R_0(1 + At + Bt^2) \quad (2)$$

with  $A = 3,9083 \times 10^{-3} / ^\circ\text{C}$  and  $B = -5,775 \times 10^{-7} / ^\circ\text{C}^2$

There is a variation in precision over the production. That's why manufacturers sort the sensors for various classes of precision (A, B, 1/3DIN B, 1/10DIN B). At 1/3 DIN B the deviation of the sensor at 0°C is specified with 0.1 K, at 100°C with 0.27K. In class 1/10 DIN the maximum deviation is reduced to 0.03K at 0°C. For higher precision it is necessary to make a multi-point calibration.

Small sensors like chip resistors show a self-heating effect which is in the range of 0.2 K/mW in air. A current of 1 mA into a PT1000 produces 1 mW dissipated power and heats it up by 200 mK. For precision applications it is therefore necessary to keep the measuring current as low as possible. This is more important the smaller the sensors are.

## 1

### Introduction

#### 1.1 PS08 PICOSTRAIN Converter

PS08 is a system-on-chip solution initially developed for weigh scale applications based on metal strain gauges. It has a PICOSTRAIN converter to measure resistance changes with 29 Bit of resolution. The proprietary 24-Bit CISC controller has access to 3 K ROM and 1 K EEPROM. In combination with the integrated LCD driver the PS08 therefore may be used as single-chip solution for temperature displays. Of course, PS08 can be used just as a converter and communicate with an external microprocessor thanks to the SPI interface.

#### 1.2 Measuring Principle

PS08 uses the PICOSTRAIN measuring principle. The resistance measurement is transferred into a precision time interval measurement.

A capacitor is discharged alternately through the sensing resistor and a reference resistor. The discharge time is set to typically  $5\ \mu\text{s}$  to  $150\ \mu\text{s}$ . It is measured with  $50\ \text{ps}$  RMS resolution ( $< 1\ \text{ps}$  by averaging). The ratio of the discharge time shows the deviation of the sensor resistance relative to the reference resistor. The current into the sensor is defined by the charge that is transported while the capacitor is discharged from  $V_{cc}$  to  $V_{th}$ . The current increases linearly with the update rate.

Figure 1

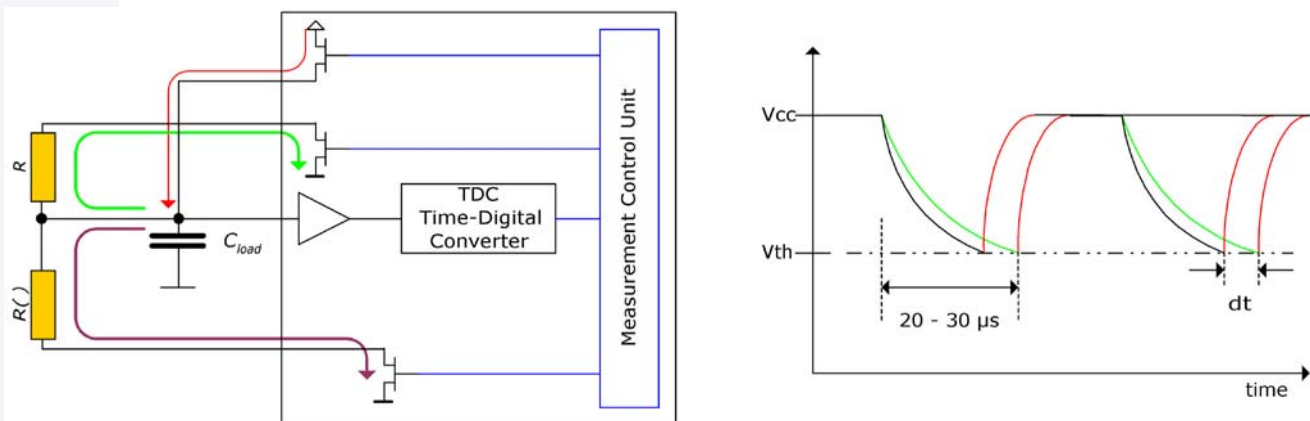

## 2 Realization, Variant 1

The following schematics shows the complete circuit for a complete PT1000 temperature electronic with optional display.

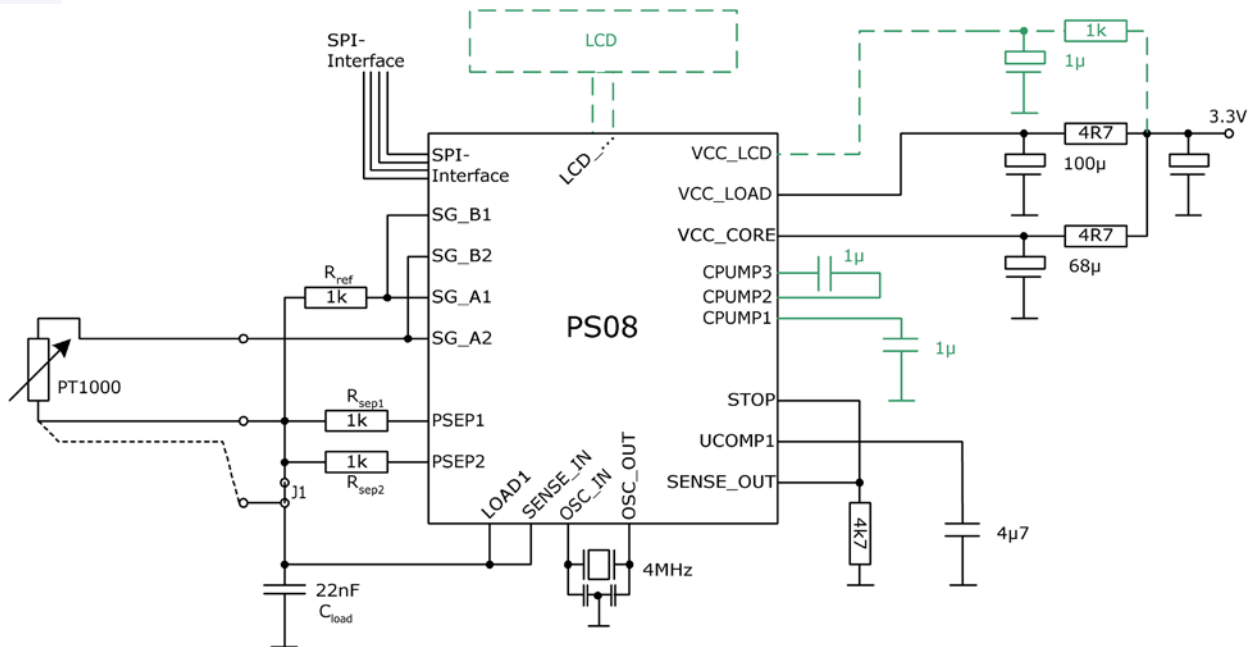

Figure 2

The PT1000 temperature sensor is compared to the fixed reference resistor  $R_{ref}$ .  $R_{ref}$  should be very stable, e.g.  $t_k = 5 \text{ ppm/K}$ , because its temperature drift effects the measurement result. The two resistors  $R_{sep1}$  and  $R_{sep2}$  may be simple metal film resistors. They are needed for correcting the gain error of the PS08 internal comparator. For the oscillator a low cost ceramic resonator should be used. PS08 has 3 separate power supplies that are all at the same voltage but should be decoupled by resistors for noise reduction.

For the discharge capacitor we chose 22 nF. The discharge time is then about 15  $\mu\text{s}$ . We use PS08 with minimum internal averaging,  $avr_{rate} = 2$ . This means, for a single measurement the capacitor is discharged two times through the temperature sensor and two times through the reference resistor.

In case PT100 should be used it is necessary to add a 50 Ohm series resistor in the common load line of  $R_{sense}$  and  $R_{ref}$ . This one guarantees even at low temperatures of-

## 2

## Realization Variant 1

125°C a minimum resistance of 100 Ohm. At lower resistance values the circuit would show non-linearity because of the limited driver power of PS08.

Thanks to the very good power supply rejection ratio (PSRR) of the PS08 it is possible to operate it directly from a battery without a voltage regulator.

### 2.1 Configuration of PS08

We configured PS08 for this temperature measurement in Single Conversion Mode, measurement range 2. In this mode the 4 MHz oscillator is active only during the measurement. As we use a ceramic oscillator with a short settling time it is sufficient to set the delay for the discharge time measurement to the smallest value 100  $\mu$ s.

```
single_conversion = 1
messb2 = 1
bridge = 1
sel_start_osz = 2
```

The cycle time (time between to discharge cycles) is set by means of the conversion counter to  $75 * 2 \mu\text{s} = 150 \mu\text{s}$ .

```
tdc_conv_cnt = 75
```

The internal comparator is also active only during the measurement.

```
sel_compint = 1
con_comp = 1
sense_discharge = 1
```

The internal multiplication factor is set to 0.1 to handle the big span of the temperature sensor.

```
Mult_Hb1 = 0,1
```

The Mult\_pp factor which corrects the comparator delay is set to 1.28.

The LCD driver is set to charge pump operation. As the voltage of the battery might vary strongly it is necessary to provide a regulated voltage to the LCD. Further LCD settings

2

Realization Variant 1

have to be selected according to the LCD technical specification.

lcd\_directdrive = 0

2.2 Program

The PS08 calculates as a raw result the ration  $(t2-t1)/(t2+t1)$ . With symmetrical sensors this would give simply the relative variation of the sensor resistance  $dR/R$ . With only one variable resistor the calculation introduces a non-linearity that has to be corrected in the program. Therefore, in a first step the program is linearized. The calculation is the following:

$$R = \left( \frac{100000 + HB0}{100000 - HB0} - 1 \right) * 1000\Omega = \frac{2HB0}{100000 - HB0} * 1000\Omega \quad (3)$$

At temperatures below 0°C we correct the resistance value by the factor  $R(t) = Ro(1+At + Bt^2 + C(t-100°C)t^3)$  . In the range from -50°C to 0°C the maximum error after this correction is 40 mΩ with PT1000.

Now we have the correct resistance in Ohm. in the next step we can calculate the temperature by means of formula (4). Therefore we rearrange formula (2):

$$T(R) = -\frac{A}{2B} + \frac{1}{2B} \sqrt{A^2 - 4B * \left( 1 - \frac{R(T)}{R} \right)} \quad (4)$$

$$T[mKelvin] = 3367879 - 1723.57352 * \sqrt{4398345 - 5.8019 * R(T)}$$

As we want to use all 24 Bit as far as possible we use bitwise shift operations. The square root is calculated according the Newton method:

$$\left( x_{n+1} = \frac{1}{2} \left( \frac{x_0}{x_n} + x_n \right) \right)$$

By selecting a good start point (x0) it is possible to stop the root calculation after 5 steps without losing resolution.

At the end of this procedure the temperature in millikelvin is available and can be displayed on the LCD.

## 2

## Realization Variant 1

**2.3 Results:****Current Consumption**

The trigger level of the internal comparator is at about 1,6 V, approximately half the supply voltage. During one capacitor discharge we see about  $1,7 \text{ V} * 22 \text{ nF}$  = 37,4 nC flowing through the resistor. At two measurements per second with two discharge cycles at the sensor the total current into the PT1000 sensor is therefore only 150 nA. The power dissipation in the sensor and as a consequence, its self-heating, can be absolutely neglected.

The complete electronic needs at 2 Hz update rate about 12  $\mu\text{A}$ , but already 6  $\mu\text{A}$  thereof are needed for the LCD which is continuously on. When being used just as a converter the complete electronic needs only 6  $\mu\text{A}$ , split in about 2  $\mu\text{A}$  base current and 2.2  $\mu\text{A}$  per measurement.

**Resolution**

The resolution of the measurement is about 0,25 m $\Omega$  RMS or 1,5 m $\Omega$  Peak-to-Peak. This corresponds to more than 20 effective bits. When recalculating temperature the converter easily reaches 1 mK resolution. The display in Kelvin is limited not by the measurement precision but by the mathematical operations and rounding errors. The program described here offers a resolution in temperature display of 3 mK. In case of a limited temperature range the resolution can be improved to 1 mK by code optimization.

**Temperature Drift of the Circuit**

The drift of the PS08 electronic, without sensor, with respect to gain and offset was measured in the temperature range -10 °C to +80 °C and a resistance span of 800 Ohms. It is less than 1 ppm F.S./°C.

### 3 Realization, Variant 2 – Minimized circuit

The circuit can be further simplified if a lower resolution is accepted. A major step is the reduction of the discharge time to 5  $\mu$ s. Then, the PS08 can be operated in measurement range 1 and a 4 MHz reference is no longer needed. A further step is to neglect the internal comparator and to use just the internal Schmitt trigger instead. This saves another resistor and capacitors. The blocking capacitors are reduced to the minimum acceptable. The circuit looks now as follows:

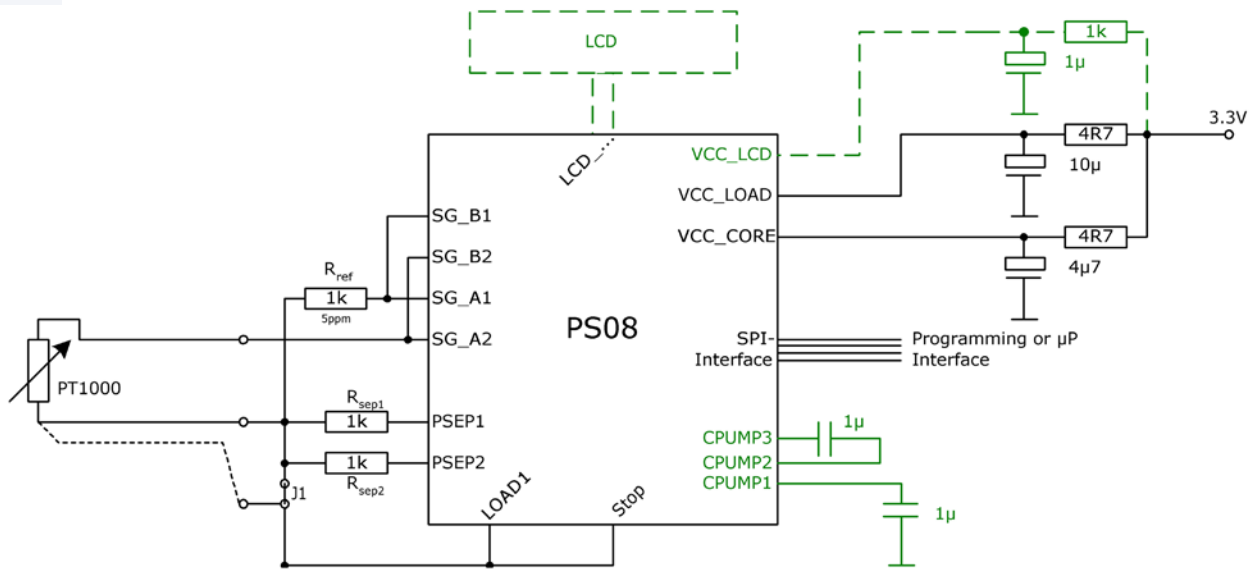

Figure 3

The circuit is reduced to only 9 components (without display). This way it is possible to make a very small and compact PCB.

Due to the smaller discharge capacitor the cable between electronic and sensor and the related parasitic capacities will have a higher effect on the measurement. The measurement is more sensitive to variations in the cable. We therefore recommend to use this circuit only in applications with short distances between electronic and sensor.

For the discharge capacitor we select 5.6 nF and get about 5  $\mu$ s discharge time. PS08 is operated with lowest averaging level,  $avr_{rate} = 2$ . For a single measurement the sensor and the reference are discharging two times each.

**3****Realization Variant 2 - Minimized**

Again, in case of PT100 it is necessary to add a 50 Ohm series resistor to the common load line. We can again drive the circuit directly from the battery without voltage regulation.

**3.1 Configuration of the PS08**

The PS08 is configured for measurement range 1, Single Conversion Mode. In this mode we use the internal 10 kHz Oscillator.

```
single_conversion = 1  
messb2 = 0  
bridge = 1  
sel_start_osz = 0
```

The cycle time (time between two discharges) is set to the lowest value, 100  $\mu$ s.

```
tdc_conv_cnt = 1
```

As we use only the Schmitt trigger we can switch off the comparator.

```
sel_compint = 1  
con_comp = 0  
sense_discharge = 0
```

The Mult\_pp factor is adjusted to the Schmitt trigger and set to 1.55.

The multiplication factor for the raw result is set to 0.1 to handle the wide span of the sensor.

```
Mult_Hb1 = 0,1
```

The LCD driver is set to charge pump operation. As the voltage of the battery might vary strongly it is necessary to provide a regulated voltage to the LCD. Further LCD settings have to be selected according to the LCD technical specification.

```
lcd_directdrive = 0
```

**3.2 Program**

There are no changes compared to variant 1.

## 3

## Realization Variant 2 - Minimized

**3.3 Results:****Current consumption**

The trigger level of the internal Schmitt trigger is about 0.8 V. At 3.3 V supply voltage we see during one discharge about  $2,5 \text{ V} * 22 \text{ nF} = 55 \text{ nC}$  flowing in the sensor. At two measurements per second, each with two discharges into the PT1000, the current into the sensor is 220 nA only. The power dissipation in the sensor is  $< 1 \text{ nW}$ . Having a platinum chip sensor with 0,15 K/mW in air still shows a negligible self heating effect. The current into the sensor increases linearly with the update rate.

The complete electronic needs about 8  $\mu\text{A}$  at 2 Hz update rate, where already 6  $\mu\text{A}$  are needed for the LCD. When used as a pure converter circuit without display then the total current is only 2  $\mu\text{A}$  at 2 Hz or 5  $\mu\text{A}$  at 5 Hz.

**Resolution**

The resolution of the measurement with this reduced circuit is about 3 m $\Omega$  RMS or 15 m $\Omega$  Peak-to-Peak. This is more than 18 effective bits. When calculating temperature we still get 4 mK rms resolution.

**Temperature Drift of the Electronic**

The temperature drift of the electronic (offset and gain) is  $< 1 \text{ m}\Omega/^\circ\text{C}$  and therefore again very good.

## 4 3-Wire Sensors

PS08 can also handle sensors with 3 wires. They are typically used to reduced the influence of the cable resistance on the measurement result. This may be necessary especially for longer cables. The cable resistance directly affects the measurement result. The critical point is that the cable resistance varies with temperature which can no longer be corrected by calibration.

For the PICO STRAIN measuring principle the variation of the cable resistance has the same effect as the change of the comparator delay. For the last PS08 has included a correction measurement procedure. With the right wiring it is now possible to correct the cable resistance together with the comparator delay. Variations of the cable resistance can be suppressed by this method by a factor of 1/1000. A variation of the cable resistance of 1 Ohm therefore changes the measurement result by only 1 mΩ.

The following picture shows the measurement paths in a 3-wire circuit. In above figures jumper J1 needs to be removed and the third wire has to be connected like the dotted line.

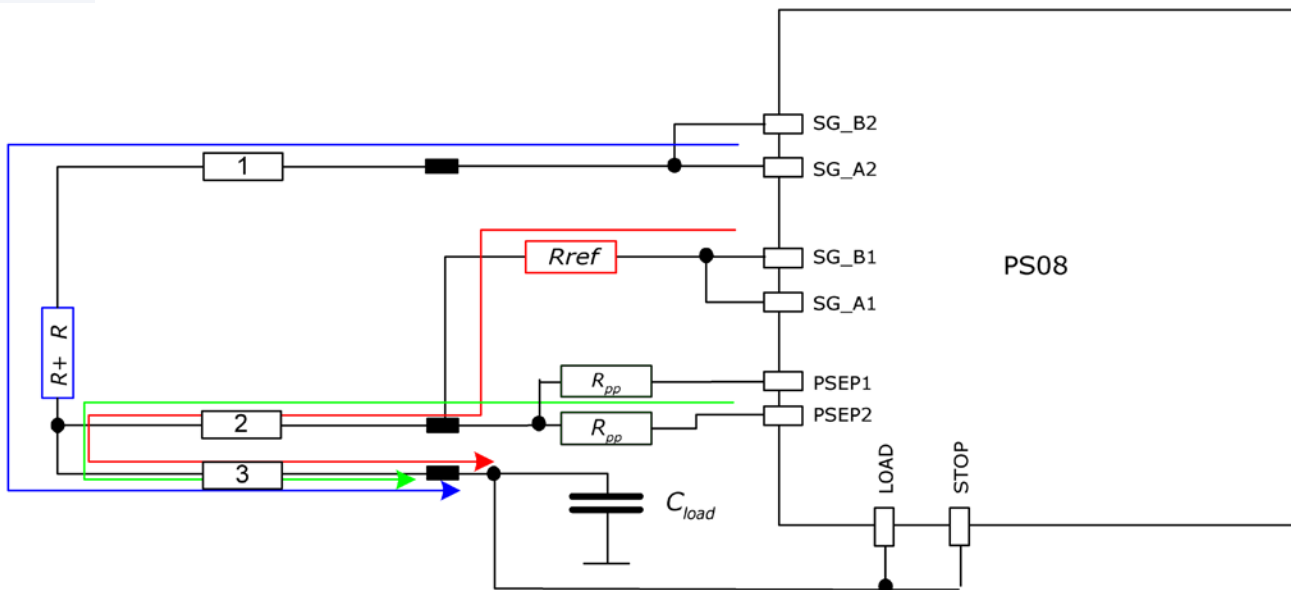

Figure 4

The 3-wire method assumes that the three wires have the same resistance and the same temperature drift. Differences in temperature drift of the wires can not be corrected and remain as an error.

## 5 Multiple channels

With PS08 it is possible to measure up to 4 sensors. The configuration is done in register 0 setting the value  $\text{bridge}[1:0] = 3$ . PS08 measures now four half bridges with each measurement and we use one and the same reference for all half bridges.

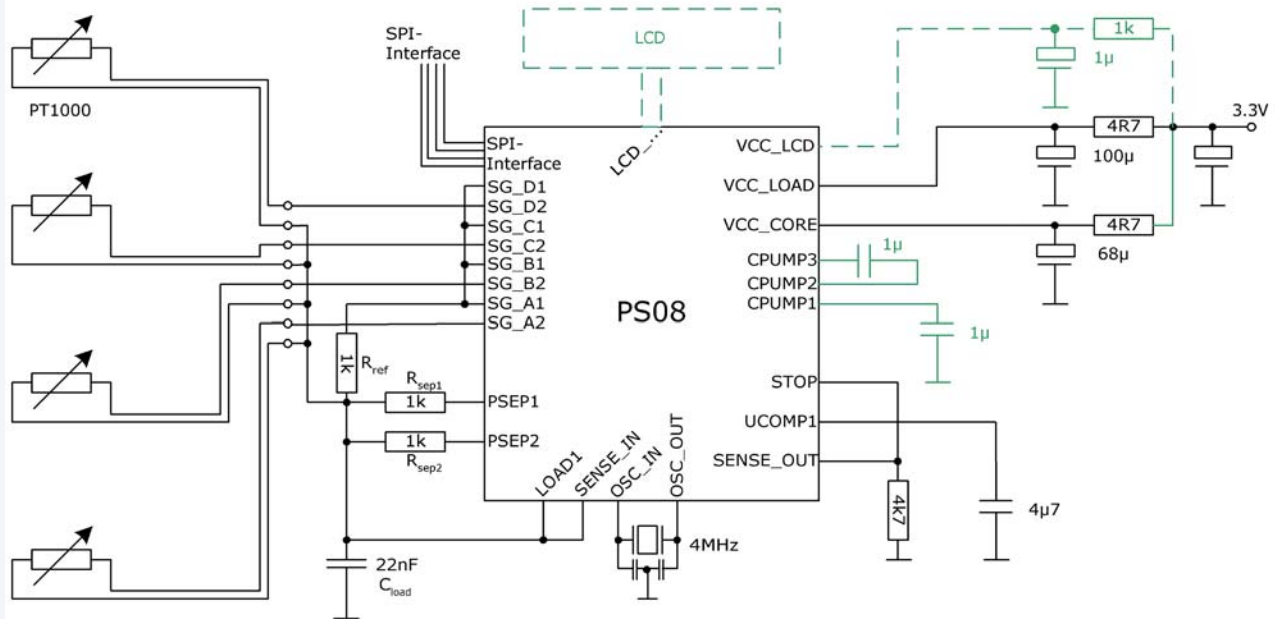

Figure 5

**6****Conclusion**

In this white paper we introduced an electronic for temperature measurement based on PSO8. It obviously differs in two features from other solutions:

- Minimum measuring current (150 nA) and therefore minimum self heating
- Minimum total current (2  $\mu$ A) in combination with high resolution (1 mK)
- Full linearization and temperature calculation done inside

It is possible to make a very compact board and still have reasonable costs for a high-resolution solution. Thanks to the internal LCD driver it is possible to make temperature displays as single-chip solution. Battery driven systems, like wireless systems, take profit from the considerably extended battery lifetime. With PSO8 it is finally possible to make solar cell driven systems.

In summary, PSO8 and its combination of high resolution with low power offers many new opportunities to temperature measurement.